

## Survey of Test Facilities for Product Qualification

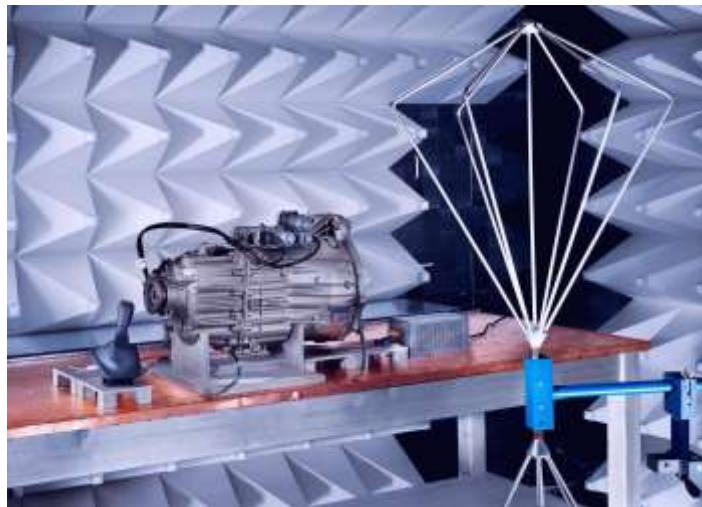

## Your Points of Contact

### General Point of Contact

Dr. Günther Appel      Phone +49 89 6088 - 3040      Fax – 3194  
 e-mail: [appel@iabg.de](mailto:appel@iabg.de)

### Vibration and Shock Test Facilities

7

Mr. Ralf Baumgartl      Phone +49 89 6088 - 2606 or - 2297      Fax - 4060  
 e-mail: [baumgartl@iabg.de](mailto:baumgartl@iabg.de)

### Hydraulic Multi-Axis Shaker

15

Mr. Wolfgang Saad      Phone +49 89 6088 - 3172 or - 3053      Fax - 2095  
 e-mail: [saad@iabg.de](mailto:saad@iabg.de)

### Climatic and Corrosive Tests

21

Mr. Tobias Müller      Phone +49 89 6088 - 2104      Fax - 3170  
 e-mail: [muellert@iabg.de](mailto:muellert@iabg.de)

### Modal Test Facilities

27

Dr. Anton Grillenbeck      Phone +49 89 6088 - 3909 or - 2703      Fax - 3964  
 e-mail: [grillenbeck@iabg.de](mailto:grillenbeck@iabg.de)

### Acoustic Test Facilities

27

Dr. Anton Grillenbeck      Phone +49 89 6088 - 3909 or - 2703      Fax - 3964  
 e-mail: [grillenbeck@iabg.de](mailto:grillenbeck@iabg.de)

### EMC Test Facility

31

Mr. Andreas Grielhüsl      Phone +49 89 6088 - 2179 or - 2619      Fax - 3970  
 e-mail: [grielhüsl@iabg.de](mailto:grielhüsl@iabg.de)

### Magnetic Test Facility

39

Mr. Rudolph Lauxen      Phone +49 89 6088 - 2693 or - 2619      Fax - 3970  
 e-mail: [lauxen@iabg.de](mailto:lauxen@iabg.de)

### Mass Properties

44

Mr. Thomas Schwab      Phone +49 89 6088 - 2170 or - 2703      Fax - 3964  
 e-mail: [schwabt@iabg.de](mailto:schwabt@iabg.de)

### DKD Calibration Laboratory for Vibration Instruments

44

Mr. Thomas Schwab      Phone +49 89 6088 - 2170 or - 2703      Fax - 3964  
 e-mail: [schwabt@iabg.de](mailto:schwabt@iabg.de) or [dkd-k-01401@iabg.de](mailto:dkd-k-01401@iabg.de)

**Calibration Facilities for Electric and Thermo-Electric Quantities**

**45**

Mr. Klaus Bayler

Phone +49 89 6088 - 2827 or - 2619 Fax - 3970  
e-mail: [bayler@iabg.de](mailto:bayler@iabg.de)

---

IABG provides comprehensive product qualification tests from one single source. Our high-capacity facilities, located in Ottobrunn near Munich, are all built according to the latest technical standards.

These days, the high requirements and standards technical equipment has to comply with concerning

- reliability
- robustness
- functionality in harsh environment
- long-term behaviour
- packaging and transport and
- conformity to laws and regulations

require solid verification using sophisticated and efficient test and verification methods. Consequently, the sustainable functionality of products under specific environmental conditions often has to be proven according to national or international standards and customer-defined specifications.

It is our daily business to practise such tests. For more than 45 years we have proven to be efficient and reliable in numerous demanding tests for many different branches.

We provide test facilities for:

### **1. Vibration and Shock**

Our vibration laboratories are equipped with an electrodynamic multi-shaker system, a hydraulic multi-axes shaker and a number of single axis shakers in different capacities.

The facilities are computer-controlled and provide the simulation of sine, random, shock and transient excitation. Digital data acquisition and processing systems provide up to 548 measurement channels (extendable up to 1,000 channels) for acceleration and 78 channels for strain or force measurements, respectively. In addition, several systems for combined vibration/temperature loading are available. Unique classical shock test machines and tools, as well as a centrifuge round off our comprehensive mechanical services.

### **2. Environmental Simulation (Temperature, Humidity, Pressure, Corrosion)**

The climatic test laboratories contain small climatic test cabinets with a testing volume of 100 up to 1,500 litres as well as accessible test chambers of approx. 10 m<sup>3</sup> up to 150 m<sup>3</sup>, partly equipped with roller type dynamometers and as vacuum test facility.

In these climatic test cabins we realise temperatures up to -70 °C and +150 °C, humidity, as well as altitude between atmospheric pressure and some hPa. Furthermore, we are able to simulate rain, icing, salt, and dust. A combined exposure to multiple additional corrosive atmospheres can also be realistically applied.

### **3. Modal Testing**

We only apply mobile test facilities allowing operation at any suitable test site outside of our laboratory in Ottobrunn. Facility sizes are starting from easily transportable equipment with 24 up to 48 measurement channels including a laser vibrometer. Our largest system is scalable in blocks of 126 channel modules and can reach up to 1,024 measurement channels overall. Electrodynamic modal exciters are available at force ratings between 10 N and 7,000 N.

Besides the modal tests with artificial excitation, we also provide comprehensive measuring and analysing services for in operation vibrations and dynamic loads.

Powerful software tools are used for test control and evaluation of the measured signals, both in the time and the frequency domain. Our comprehensive modal analysis tools enable customised solutions for even unconventional testing tasks in the sphere of aeronautics and general engineering.

### **4. Acoustics**

In our reverberation chamber which measures 1,378 m<sup>3</sup> acoustic noise tests are performed to qualify test objects against the

acoustic environment up to 156 dB. In a special progressive wave tube even higher acoustic noise levels up to 170 dB can be achieved. Up to 256 response measurements can be taken during such tests, and up to 24 microphones are installed for the control of the noise field. This measurement capacity may easily be expanded by making use of the communality of all our measurement systems.

Moreover, two acoustic laboratories provide means for sound power measurements and transfer path analyses. This is of particular interest for general engineering and automotive applications.

## 5. EMC

The EMC test facilities provide three shielded anechoic chambers with pyramid absorbers and a shielded anteroom. Frequency domain emission tests can be performed with automatic EMI receivers up to 50 GHz and time domain measurements with scopes up to 5 GS/s. Susceptibility test equipment allows to generate frequencies up to 40 GHz. Electromagnetic field levels of more than 3,000 V/m can be excited. Lightning, ESD, and power simulation (transients and interruptions) can be carried out.

Our test equipment and our wide infrastructure even allow very complex test objects to be qualified according to most EMC industrial standards or specific customer requirements.

## 6. Magnetics

The magnetic test facility consists of a non-magnetic wooden building with a measuring volume of 8,000 m<sup>3</sup>. It is based on a non-reinforced concrete foundation. For simulating magnetic fields square coil systems in 3 orthogonal axes (4 coils per axis) with a volume of 15 m x 15 m x 15 m are in use.

With this coil system the earth field can be compensated, or DC and AC fields can be generated. A computer controlled data ac-

quisition system is available to measure the magnetic field in 3 axes. It can also be used for further evaluation.

In addition, test specimen can be magnetised or demagnetised by using a special coil system.

According to ISO 10373 and ISO 7816 Identification Cards as vicinity or proximity cards or cards with magnetic strips or integrated circuits can be tested with magnetic fields up to 800,000 A/m.

## 7. Mass Properties

For any kind of general engineering systems a number of facilities are available for the accurate determination of the mass properties. We determine mass (weight), centre of gravity and moment of inertia. Furthermore, static and dynamic balancing can be performed.

## Location of the Product Qualification Test Facilities

All environmental simulation facilities are located at IABG in Ottobrunn near Munich:

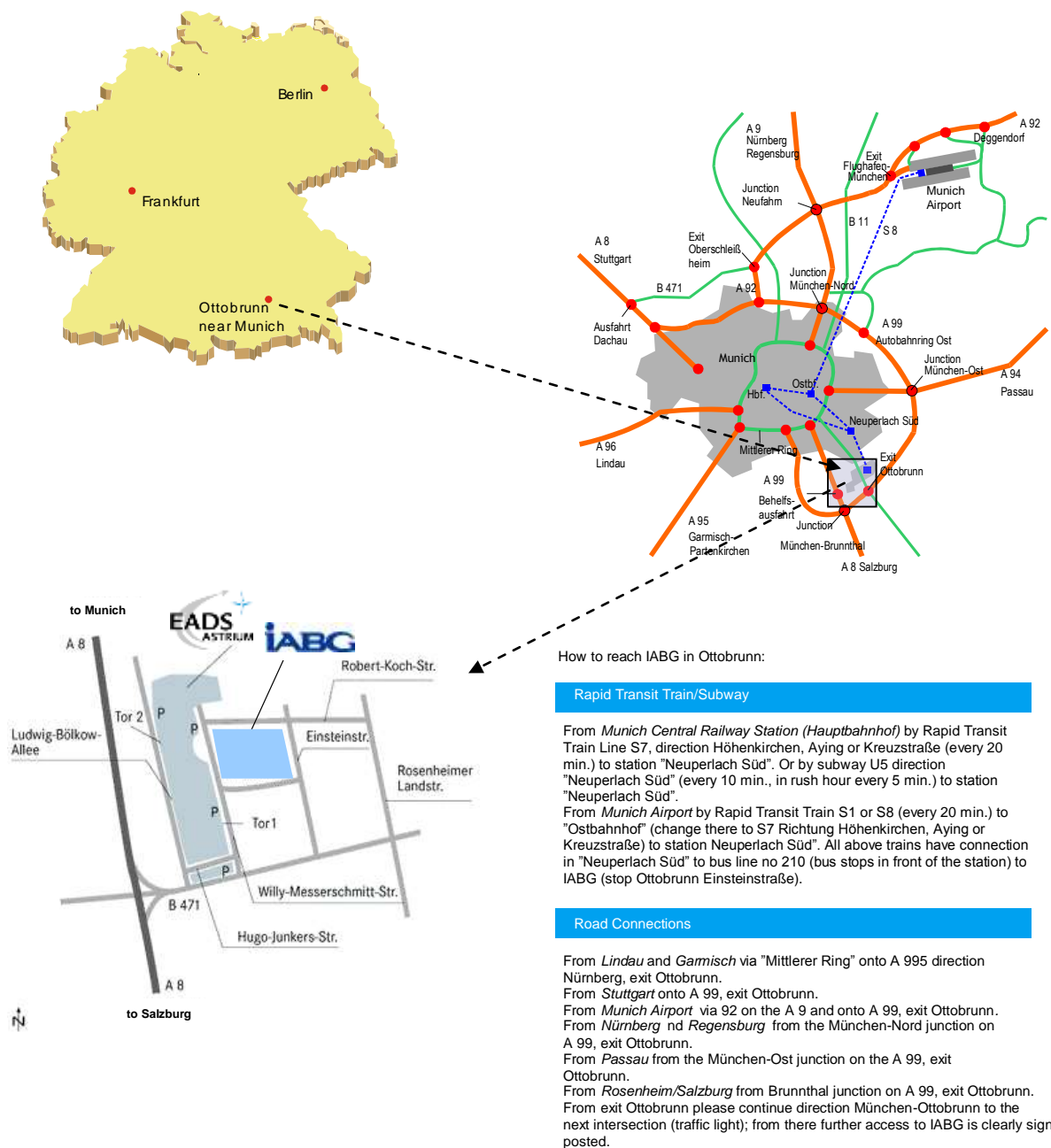

*Product Qualification*

## Mechanical Test Facilities



*300 kN Multi-Shaker System with a main landing gear*

## 1. Tasks

- Dynamic load tests for development and qualification
- Experimental simulation of real loads
- Measurements of real operational loads
- Measurement and analysis of operational vibration responses
- Specialist's advice

## 2. Test Facilities

The vibration laboratories operate several vibration facilities with graded capacities and force vectors from 36 kN to 320 kN.

A data acquisition system with 548 channels is available for the measurement and evaluation of the test object responses. The main sensor types used are accelerometers, strain gages and load cells.

The digital measurement data can be provided in various established formats (e.g. unv-file or DynaWorks) for extensive post processing and prediction on-site which makes further data processing convenient for our clients.

The vibration facilities are equipped with standard test fixtures and slip tables in order to expose the test objects to uniaxial loads in the three orthogonal axes.

Three facilities with a force rating of up to 50kN are equipped with thermal chambers working in the temperature range of -70 °C to +180 °C.

Extreme environmental situations such as earthquakes or transient events (gust loads, airplane crash etc.) can be simulated by the multi-axes shaker "HyMAS" (see Fig. 1). The shaker is driven by four vertical and three horizontal hydraulic actuators and thus allows a spatial movement in all six degrees of freedom.



### 3. Technical Data

#### 3.1 Multi-Shaker System, 200 kN and 80 kN Shaker

##### 3.1.1 Multi-Shaker System (VVS)

Force rating:	320 kN sine 300 kN random
Max. acceleration:	bare table: 15 g with 3,000 kg payload: 6 g
Min. controllable level:	0.05 g
Max. displacement:	± 12 mm
Frequency range:	4 - 300 Hz high level 300 - 2,000 Hz reduced level
Max. payload mass (table excl.):	3,000 kg (with standard load suspension) 10,000 kg (with external suspension)
Usable surface area:	2,9 m x 2,9 m, with 80 x 80 mm <sup>2</sup> hole pattern, M10

##### 3.1.2 Vibration System (4022 LX)

Force rating:	200 kN sine 160 kN random
Max. acceleration:	bare standard table: 40 g with 500 kg payload: 20 g
Min. controllable level:	0.05 g
Max. displacement:	± 15 mm
Frequency range:	4 – 2,000 Hz
Max. payload mass:	900 kg (table excl.)
Usable surface area:	1.3 m x 1.3 m, with 80 x 80 mm <sup>2</sup> hole pattern, M10

### 3.1.3 Vibration System (V964LS)

Force rating:	80 kN sine, random
Max. acceleration:	100 g
Min. controllable level:	0.05 g
Max. displacement:	± 15 mm
Frequency range:	5 – 2,500 Hz
Max. payload mass (table excl.):	750 kg
Usable surface area:	1,0 m x 1,0 m with 80 x 80 mm <sup>2</sup> hole pattern, M10

### 3.1.4 Vibration Control

Two digital control systems equipped with:

- LMS CadaX / LMS Test.Lab Software on a hp-ux computer / Windows PC  
excitation: sine, random, shock, transient
- 36 / 48 input channels (pilots + limiter channels), on-line monitoring of selected channels, automatic notch and abort functions, external low-pass filtering  
“easy link” (24 lines) to the data acquisition system
- safety features  
emergency button (soft shut-down) on all facilities  
redundant safety circuit for test facility surveillance

### 3.1.5 Measurement Equipment

800 accelerometers (various types for specific applications) mainly ICP with full scale ranges from milli-g up to 200,000 g

Strain gages of different types

### 3.1.6 Data Acquisition and Processing

548 measurement channels (extendable up to 1,000):	up to 2.0 kHz
78 signal conditioners for strains and forces:	up to 2.0 kHz
Data output formats:	Universal-File Format DYNAWorks-File Format PDF Diagrams

### 3.1.7 Force Measurement Device (FMD)

Versatile force link set-up for the online determination of interface forces and moments	
Number of load cells:	16
Maximum force	2400 kN vertical 480 kN lateral
Number of signal conditioners	80 channels (charge)
Online determination of summed forces and moments	20 channels
Frequency range	up to 200 Hz

## 3.2 Further Vibration Systems

### 3.2.1 Vibration System (A540) with Temperature Chamber

Force rating:	53 kN sine, random
Max. acceleration:	45 g
Min. controllable level:	0.1 g
Max. displacement:	± 12 mm
Frequency range:	5 – 2,000 Hz
Max. payload mass (table excl.):	500 kg
Usable surface area:	0.76 m x 0.76 m with 40 x 40 mm <sup>2</sup> hole pattern, M8
Usable volume of temperature chamber:	1.2 m x 1.2 m x 1.2 m
Temperature range for vibration tests:	- 40 °C up to + 120 °C
Temperature transient:	≤ 4 °C (heating) ≤ 2 °C (cool down)

#### 3.2.1.1 Vibration Control System

- M + P
- 16 channels, sine, random, shock, SOR, ROR

### 3.2.2 Vibration System (R16C-3)

Force rating:	57 kN sine, random
Max. acceleration:	118 g
Min. controllable level:	0.1 g
Max. displacement:	± 25 mm sine, random ± 35 mm shock, transient
Frequency range:	5 – 3,000 Hz
Max. payload mass (table excl.):	500 kg
Usable surface area:	0.7 m x 0.7 m with 40 x 40 mm <sup>2</sup> hole pattern, M8

### 3.2.2.1 Vibration Control System

- M + P
- 16 channels, sine, random, shock, SOR, ROR

### 3.2.3 Vibration System (V875) with Temperature Chamber

Force rating:	36 kN sine, random
Max. acceleration:	110 g
Min. controllable level:	0.1 g
Max. displacement:	± 15 mm sine, random ± 20 mm shock, transient
Frequency range:	5 – 3,000 Hz
Max. payload mass (table excl.):	600 kg
Usable surface area:	0.6 m x 0.6 m, (vertical d = 0.65 m) with 40 x 40 mm <sup>2</sup> hole pattern, M8
Usable volume of temperature chamber:	1.2 m x 1.2 m x 1.2 m
Temperature range for vibration tests:	- 40 °C up to + 150 °C (-60°C in vertical excitation)
Temperature transient:	≤ 7 °C

### 3.2.3.1 Vibration Control

- M + P
- 24 channels, sine, random, shock, SOR, ROR

### 3.2.4 Vibration System (59350) with Temperature Chamber (only vertical excitation)

Force rating:	49 kN sine, random
Max. acceleration:	100 g
Min. controllable level:	0.1 g
Max. displacement:	± 15 mm sine, random ± 20 mm shock, transient
Frequency range:	5 – 3,000 Hz
Max. payload mass (table excl.):	500 kg

Usable surface area:	0.6 m x 0.6 m with 40 x 40 mm <sup>2</sup> hole pattern, M8
Usable volume of temperature chamber:	1.2 m x 1.2 m x 1.2 m
Temperature range:	- 60 °C up to + 150 °C
Temperature transient:	≤ 7 °C

#### **3.2.4.1 Vibration Control System**

- M + P
- 8 channels, sine, random, shock, SOR, ROR

### 3.3 Multi-Axis Shaker



Fig. 1: Multi-Axis Shaker HyMAS



Fig. 2: Multi-Axis Shaker HyMAS

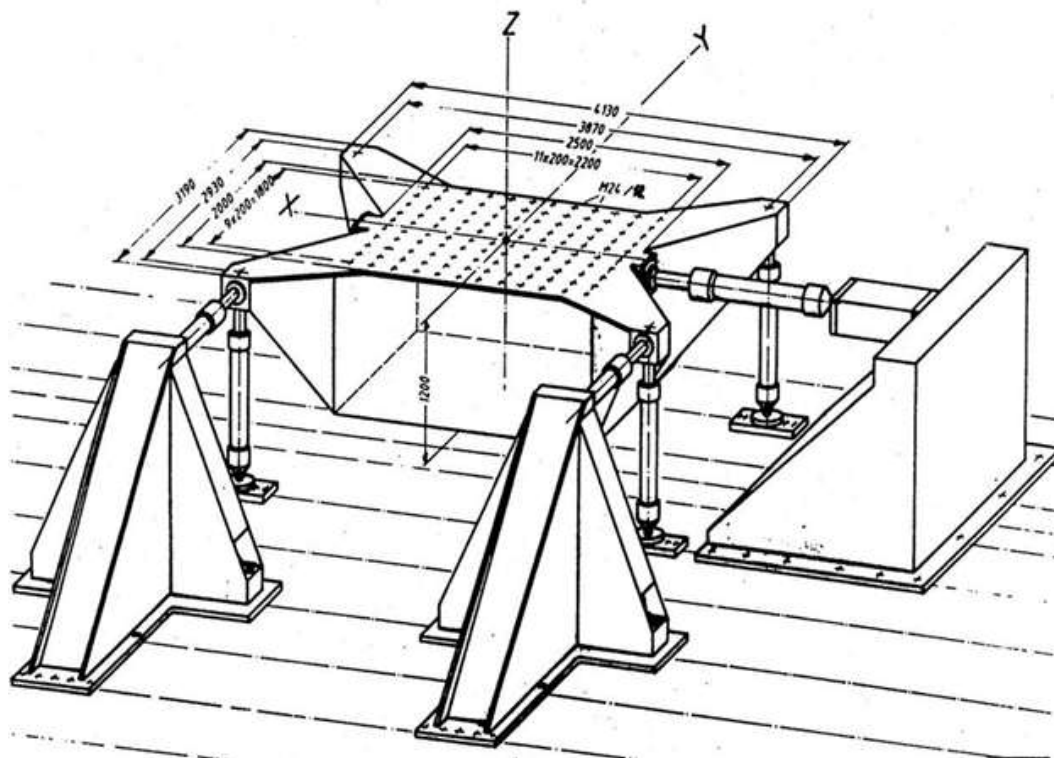

Fig. 3: Earth Quake Table



## Multi-Axis Shaker (HyMAS)

Vibrations may either occur during operation or transport or under extreme environmental situations such as earthquakes. They may also be caused by transient events such as gusts. As a consequence, vibrations can damage technical equipment and thus cause (high) costs due to repair or substitution of equipment.

With our highly sophisticated hydraulic multi-axis shaker HyMAS, individual tests can be performed according to customer specifications in order to simulate such

vibrations and thus discover possible technical weak points. HyMAS enables us to discover them either already during the construction phase or during production. Failures can therefore be avoided.

The data acquisition and evaluation system of HyMAS is able to simultaneously measure and evaluate up to 64 channels.

Within its performance and design limits, the shake system can be operated with the following sinusoidal test signals:

Type:	Frequency:	Amplitude:	Standard:
Continuous sine	constant	constant	EN 60068-2-6
Sine sweep	continuous linear or exponential	regulated to constant value	EN 60068-2-6
Sine beat	constant	sinusoidal modulation	EN 60068-2-59

### 3.3.1 Performance Data for HyMAS Shaker Table

Table dimensions:	4.1 m x 3.2 m	
Fixing surface:	2.5 m x 2 m, with 200 x 200 mm <sup>2</sup> hole pattern, M24	
Table mass:	4,348 kg	
Max. test specimen mass:	10,000 kg	
Frequency range:	0.1 – 100 Hz	
Natural frequency of foundation:	0.7/1.2 Hz	
Number of cylinders:		
Horizontal:	x	1
Horizontal:	y	2
Vertical:	z	4
Cylinder force each:	x	250 kN
	y	100 kN
	z	100 kN
Max. amplitudes:	x	+/- 125 mm
	y	+/- 125 mm
	z	+/- 50 mm
	$\phi_x$	+/- 0.0326 rad/s
	$\phi_y$	+/- 0.0247 rad/s
	$\phi_z$	+/- 0.0658 rad/s
Max. velocities:	$\dot{x}$	0.43 m/s
	$\dot{y}$	0.53 m/s
	$\dot{z}$	0.26 m/s
	$\dot{\phi}_x$	+/- 0.0204 rad/s
	$\dot{\phi}_y$	+/- 0.0155 rad/s
	$\dot{\phi}_z$	+/- 0.0413 rad/s
Max. accelerations:	$\ddot{x}$	50 m/s <sup>2</sup>
	$\ddot{y}$	40 m/s <sup>2</sup>
	$\ddot{z}$	80 m/s <sup>2</sup>
	$\ddot{\phi}_x$	+/- 0.0129 rad/s <sup>2</sup>
	$\ddot{\phi}_y$	+/- 0.0097 rad/s <sup>2</sup>
	$\ddot{\phi}_z$	+/- 0.0259 rad/s <sup>2</sup>

### 3.4 Shock Facilities and Centrifuge

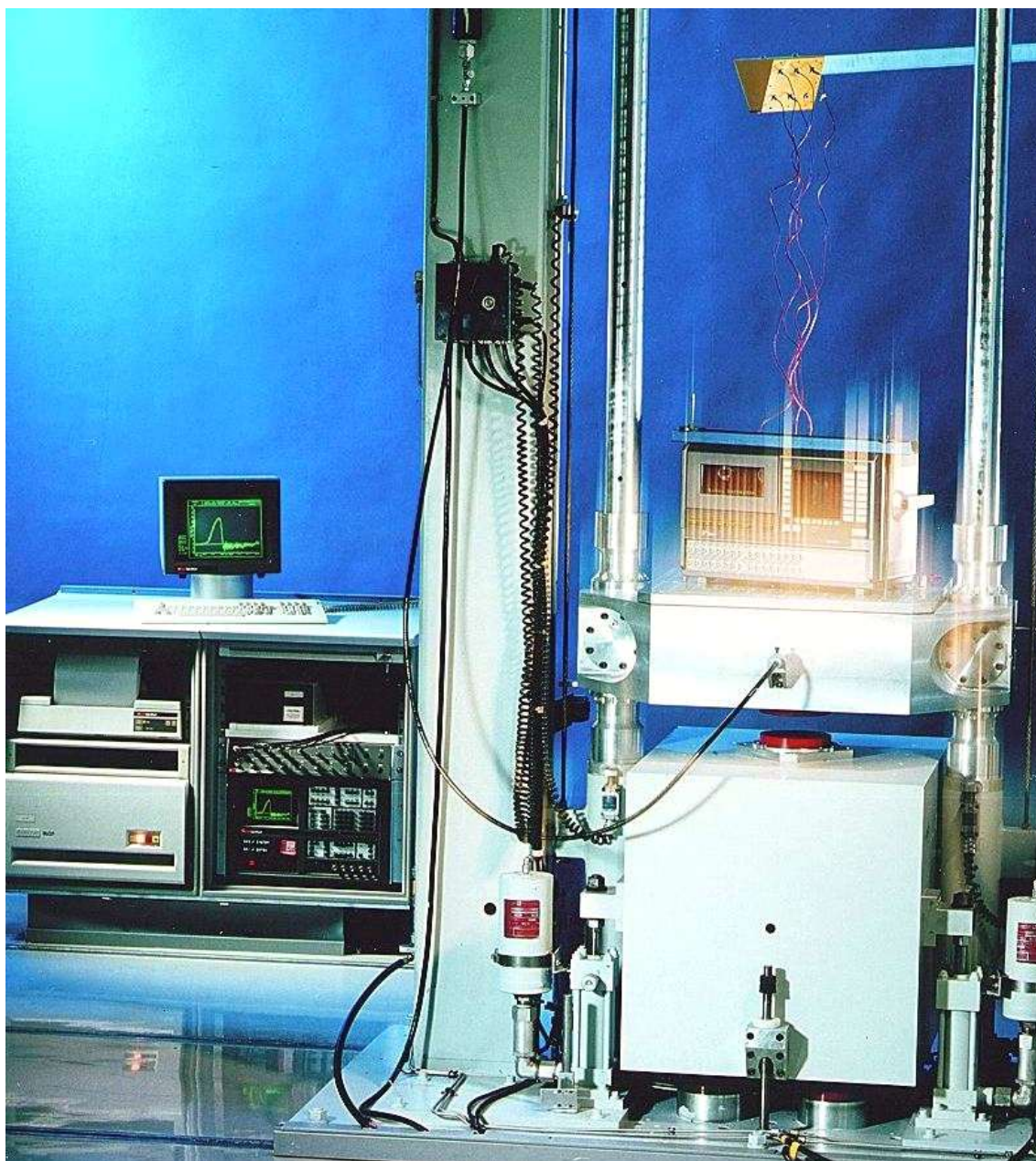

Fig. 2: Drop Shock Facility IMPAC

### 3.4.1 Drop Shock Facility IMPAC 2424

Max. acceleration:	2,000 g
Shock duration:	100 - 1 ms
Pulse type:	Half-Sine
Max. payload mass:	500 kg
Usable surface area:	0.6 m x 0.6 m with 40 x 40 mm <sup>2</sup> hole pattern, M8
Max. sample width:	0.6 m

### 3.4.2 Drop Tower

Max. acceleration:	15,000 g
Shock duration:	0.2 - 3 ms
Pulse type:	Half-Sine
Max. payload mass:	2 kg
Usable surface area:	110 mm x 110 mm circular hole pattern, M10

### 3.4.2 Pyroshock Simulation Facility

Frequency range:	100 - 10,000 Hz
Max. acceleration:	10,000 g (SRS)
Pulse type:	Transient
Shock duration:	< 10 ms

### 3.4.2 Acceleration Test Facility

Acceleration:	1 – 100 g (at 50 inch radius)
Max. rotary speed:	300 1/min
Max. sample mass:	40 kg
Fixation height:	0.5 m
Usable surface area:	0.5 m x 0.5 m with 40 x 40 mm <sup>2</sup> hole pattern, M8

*Product Qualification*

## Climatic Chambers



*Climatic tests on a train door*



*Climatic tests on a car*

## 1. Tasks

- Simulation of high and low temperatures
- Humidity simulation (damp heat, cyclic and constant)
- Simulation of rainfall, icing and dewing
- Simulation of altitude (variation of pressure from ambient up to some hPa)
- Creation of temperature shocks
- Simulated radiation according to daylight phase D 65
- Simulation of corrosive atmospheres (salt spray test, SO<sub>2</sub> and H<sub>2</sub>S dew test)
- Consultancy in the field of environmental testing

## 2. Test Facilities

We operate several climatic test chambers with test capacities from 0.1 m<sup>3</sup> to 150 m<sup>3</sup>. The temperature ranges between -70 °C and + 180 °C. Controlled humidity as well as temperature shocks in air and with water, fast temperature changes (up to 15 K/min) and cyclic salt spray tests can be realised in these chambers.

Six easily accessible and driveable test chambers with a volume of up to 150 m<sup>3</sup>

allow complete cars and partly also trucks to be tested under simulated environmental conditions.

Several chambers are equipped with roller type dynamometers.

In some of our test facilities we also simulate solar radiation, dust, rain, icing, dewing and air pressure.

### 3. Technical Data

#### 3.1 Large Climatic Test Chamber

Testing capacity:	8.5 m x 4.5 m x 4.3 m (L x W x H)
Temperature range:	- 30 °C up to + 50 °C
Controlled humidity:	up to 95 % r.h.
Pressure:	from environmental pressure up to 630 hPa
Refrigerating capacity:	up to 180 kW
Roller type dynamometer:	P_max = 210 kW, v_max = 200 km/h
Airstream compressor:	up to 34,000 m <sup>3</sup>
Exhaust gas measuring system:	CVS

#### 3.2 Vehicle Test Chamber I

Testing capacity:	7.0 m x 3.5 m x 2.6 m (L x W x H)
Temperature range:	- 70 °C up to + 80 °C
Humidity:	uncontrolled
Pressure:	ambient
Refrigerating capacity:	max. 190 kW
Roller type dynamometer:	P_max = 40 kW

#### 3.3 Vehicle Test Chamber II

Testing capacity:	8 m x 5 m x 2.55 m (L x W x H)
Temperature range:	- 30 °C up to + 60 °C
Humidity:	uncontrolled
Pressure:	ambient
Refrigerating capacity:	max. 110 kW
Roller type dynamometer:	P_max = 53 kW

### 3.4 Altitude Test Chamber

Testing capacity:	5.8 m x 2.5 m x 3.0 m (L x W x H)
Temperature range:	- 70 °C up to + 80 ° C
Humidity:	uncontrolled
Pressure:	from ambient up to 50 hPa

### 3.5 Temperature Test Chamber

Testing capacity:	5.5 m x 4.5 m x 4 m (L x W x H)
Temperature range:	- 75 °C up to + 150 °C
Humidity:	uncontrolled
Pressure:	ambient
Refrigerating capacity:	max. 150 kW

### 3.6 Solar Radiation Test Chamber

Usable radiation testing area:	2.0 m x 3.0 m (L x W), adjustable ground level
Radiation:	700 W/m <sup>2</sup> up to 1,200 W/m <sup>2</sup>
Radiation constance:	± 5 %
Temperature range:	- 30 °C up to + 90 °C
Controlled humidity:	up to max. 95 % r.h.

### 3.7 Climatic Test Chamber

Testing capacity:	9.5 m x 4.5 m x 4.0 m (L x W x H)
Temperature range:	- 40 °C up to + 120 °C
Pressure:	ambient
Controlled humidity:	up to max. 95 % r.h.
Refrigerating capacity:	max. 120 kW



### 3.8 Temperature Shock Chamber

Testing capacity:	0.65 m x 0.47 m x 0.4 m (L x W x H)
Temperature range:	- 80 °C up to + 220 °C
Pressure:	ambient
Humidity:	uncontrolled
Temperature change:	approx. 3 sec
Max. mass of test sample	≤ 20 kg

### 3.9 Multi Purpose Test Chamber

Testing capacity:	4 m x 2.2 m x 2.8 m (L x W x H)
Temperature range:	- 70 °C up to + 120 °C
Temperature transient:	≤ 4 °C /min
Pressure:	ambient
Controlled humidity:	up to max. 95 % r.h.

### 3.10 Multi Purpose Test Cabinet (BFV64)

Testing capacity:	1.12 m x 0.79 m x 0.7 m (L x W x H)
Temperature range:	- 75 °C up to + 150 °C
Temperature transient:	≤ 5 °C /min
Temperature constance:	± 1 °C
Pressure:	25 hPa up to 1,070 hPa
Icing:	e.g. according to RTCA/DO -160D
Controlled humidity:	up to max. 95 % r.h.

### 3.11 Stress Screening Cabinet

Testing capacity:	0.875 m x 0.88 m x 0.94 m (L x W x H)
Temperature range:	- 70 °C up to + 180 °C
Temperature transient:	max. 10 °C /min
Pressure:	ambient

### 3.12 Climatic Stress Cabinet

Testing capacity:	0.65 m x 0.80 m x 0.95 m (L x W x H)
Temperature range:	- 70 °C up to + 180 °C
Temperature transient:	max. 15 °C /min
Pressure:	ambient
Controlled humidity:	up to max. 95 % r.h.

*Product Qualification*

## Modal Test Facility



*Structure test on a vehicle body*

## 1. Tasks

- Experimental and analytical vibration investigations, also comprising dynamic and static stiffness measurements
- Determination of the modal characteristics of mechanical structures
- Test-assisted development and verification of mathematical models
- Design and testing of measures to remedy dynamic vibration problems
- Optimisation of the dynamic behaviour of mechanical systems
- Design of fixtures for dynamic testing applications
- Consultancy in the field of structure dynamics

## 2. Test Facilities

Electro-dynamic exciters from 10 N to 7 kN (sine) for the dynamic loading of test objects are available for the experimental vibration investigations.

We operate several mobile modal test systems of different sizes for the excitation control, measurement and analysis of artificially or naturally excited dynamic responses:

- Small systems with up to 48 channels for mobile measurements in vehicles (12 V DC supply),
- Larger systems composed of modules with 126 channels each for classical modal survey tests,
- Maximum facility size 1,024 measurement channels
- Universal use for sine and random testing as well as for in operation vibration measurements in the frequency range of 0.5 Hz to 40 kHz

All facilities are mobile and can be used at short notice on any test site. This equipment is completed with an optical (laser) measurement system for contact-less measurements of vibrations.

The test performance is computer controlled. The evaluation of the measured signals and the presentation of the test results are conducted with the help of sophisticated up-to-date software tools.

Our structure test hall provides a seismic foundation of 240 metric tons for a rigid fixing of the test objects.

A large assortment of sensors for acceleration, velocity, displacement, strain, force, pressure and temperature enables the investigation of complex vibration and related interdependences under even extreme conditions.

### 3. Technical Data

#### 3.1 Excitation

Sine wave generators:	up to 10 kHz
Random noise generators:	up to 25 kHz
Simultaneous control:	sine: 12 channels random: 12 channels
Vibration exciters:	10 N up to 7,000 N
Instrumented hammers:	140 g up to 5 kg

#### 3.2 Measurement

400 standard accelerometers: with sensitivity values ranging from	ranges from 5 to 5,000 m/s <sup>2</sup> and 10 kHz 10 mV/g to 10 V/g
--	---

Additional transducers for velocity, displacement, force, strain and special environmental conditions, also further accelerometers can be made available.

#### 3.3 Data Acquisition

Sine / Random:	
Up to 1,024 channels:	0.5 Hz to 40 kHz
Data base:	Universal Files and Dynaworks further data formats on request

#### 3.4 Computer Systems

Networked PC work stations and laptops.  
Efficient and sustainable data archiving  
High quality colour printers  
Software tools for signal processing, modal analysis and results visualization

*Product Qualification*

## Acoustic Test Facility



*Noise Path Analysis*

## 1. Tasks

Acoustic noise tests are performed to qualify the test object against the extreme acoustic environments typically encountered in aerospace applications. These tests are performed in reverberation chambers and progressive wave tubes.

In contrast to this, product qualification, comfort aspects, and legal requirements raise the need for sound power measurements, the determination of transfer paths, and the assessment of noise reduction measures. These tasks may also be performed in our reverberation chamber or in semi-anechoic and hemi-anechoic chambers available on site.

## 2. Test Facilities

For the performance of acoustic noise tests we use an acoustic facility with a reverberation chamber of  $V = 1,378 \text{ m}^3$  (max. 156 dB OASPL), and a progressive wave tube for high intensity (170 dB OASPL) acoustic tests. Semi-anechoic and hemi-anechoic chambers augment the spectrum of acoustic test capabilities at IABG.

In the reverberation chamber, the test object is exposed to a diffuse sound field

with sound waves impinging from all directions. The noise generation system is based on three air compressors providing a maximum air flow of 6 kg/s for three noise generators and horns. The test control and measurement system consists of 24 microphone control channels and of 256 regular response channels.

In the anechoic chambers the sound power levels, sound propagation and transfer path analyses can be performed by using a mobile measurement facility.

### 3. Technical Data

#### 3.1 Reverberation Chamber

Chamber, height x width x depth (cube):	15.2 m x 10.4 m x 8.4 m
Crane capacity:	16,000 kg
Max. acoustic power:	3 x 30 kW ac
OASPL (broadband):	156 dB
Acoustic spectrum:	25 Hz $\leq$ f $\leq$ 10 kHz
Duration of noise exposure:	unlimited
Data acquisition and reduction:	24 microphone channels 256 response data channels 1/1 oct.-, 1/3 oct.-, 1/12 oct.- PSD- Analysis, RMS values, correlation and other statistical functions

#### 3.2 Progressive Wave Tube

Test section:	0.8 m x 1.2 m
Max. acoustic power:	90 kW ac
OASPL (broadband):	170 dB
Acoustic spectrum:	25 Hz $\leq$ f $\leq$ 10 kHz
Duration of noise exposure:	unlimited
Data acquisition and reduction:	12 microphone channels 48 response data channels 1/1 oct.-, 1/3 oct.-, 1/12 oct.- PSD- Analysis, RMS values, correlation and other statistical functions



### 3.3 Hemi- and Semi-Anechoic Chamber

For basic tests on sound propagation and transfer path analysis, hemi- and semi-anechoic chambers are available to realize the free field tests on industrial products, especially for the automotive industry.

- Measurement of sound pressure levels
- Determination of mechanical-acoustic transfer functions
- Measurements according to DIN ISO 3741 ff, quality grades 1 and 2

In detail, following test enquiries can be performed:

#### Semi-anechoic measurement room

Dimensions:	7 m x 7 m x 7 m
Effective area of test section:	49 m <sup>2</sup>
Equipment and fixtures:	Sensors for acoustic pressure und acceleration measurements Lifting-jack hoist for inquiries on passenger cars
Data acquisition and evaluation:	Several mobile data acquisition and processing facilities

#### Hemi-anechoic measurement room

Hemi-anechoic measurement room	According to DIN EN ISO 3745.2
Dimensions:	7 m x 7 m x 7 m
Effective area of test section:	49 m <sup>2</sup>
Equipment and fixtures:	Sensors for acoustic pressure und acceleration measurements
Data acquisition and evaluation:	Several mobile data acquisition and processing facilities

*Product Qualification*

## EMC Test Facilities



*EMC tests on automotive gear*

## 1. Tasks

At IABG, the following EMC qualification and engineering tests according to international standards or product requirements can be performed:

- Aviation Standards, such as  
RTCA/DO-160  
Airbus ABD0100, AMD-24  
Eurocopter Tiger, NH90, EC135  
Boeing D6-16050-4
- Military Standards such as  
MIL-STD-461/462/464  
MIL-STD-704E  
MIL-STD-1275  
MIL-STD-1399
- Automotive Standards, such as  
72/245/EWG, 95/54/EWG  
CISPR 25, VDE 0879  
ISO-7637-x, ISO 11451/11452-x

VW TL 965, TL 82xxx  
MBN 10284-2

- Space Standards, such as  
SSP20237/20238, ECSS-20-07
- Special customer requirements

Supplementary services:

- Emission and susceptibility testing
- Measurement of shielding attenuation
- High intensity radiated fields (HIRF)
- Lightning with multiple burst & stroke
- Simulation of mobile communication on GSM Frequencies
- Power characteristics and simulation
- Consulting and hardening

## 2. Test Facility

The EMC test facility is accredited by DATech according to ISO/IEC 17025 and certified according to ISO 9001.

System and component tests are carried out in two medium and one large shielded anechoic chamber with a shielded ante-room.

Emissions are measured by computer-controlled EMI receiver systems. Susceptibility tests and calibration are performed by software-controlled equipment.

With state-of-the-art receivers conducted and radiated emissions can be measured up to 50 GHz. For susceptibility tests and calibration setups a pool of several generators and power amplifiers is available. With special high power amplifiers and high gain antennas fields of more than 2,000

V/m can be generated for HIRF tests (see

Fig. 3).

By means of this equipment EMC tests can be conducted in the range from 10 Hz to 40 GHz, in compliance with the applicable standards.

The measurement capabilities are completed by equipment for time domain tests. In addition to the above mentioned tests also electrostatic discharge, burst and surge according to the civil EN-61000 standard series as well as aircraft and military requirements such as lightning (LEMP) with multiple stroke and multiple pulse and damped sinusoidal pulses (NEMP) can be simulated.

Beyond the classical EMC tests, we further cover electrical tests and simulation of power supply systems (interruptions, modulations overvoltage, break-down, surges).

### 3. Technical Data

#### 3.1 Chamber Characteristics

	EMC Chamber 1	EMC Chamber 2
Length x width x height:	10.5 m x 7.2 m x 8.2 m	5.4 m x 4.3 m x 2.7 m
Anteroom:	6.5 m x 9 m x 3.5 m	2.7 m x 6.3 m x 2.8 m
Max. floor load:	29 kN/m <sup>2</sup>	30 kN/m <sup>2</sup>
Single point load:	10 kN/m <sup>2</sup> unit	5 kN/m <sup>2</sup> unit
Dimensions of door, width x height:	6 m x 4 m	0.89 m x 1.9 m
Cleanliness class (ISO14644-1):	8	-
Temperature:	adjustable from 19 °C – 25 °C stability ± 1 °C	adjustable from 19 °C – 25 °C stability ± 1 °C
Relative humidity:	adjustable from 40 % - 60 % stability ± 5 %	adjustable from 40 % - 60 % stability ± 5 %
Compressed air and water supply:	available	available
Exhaust tail pipe:	available	-
Hoisting equipment:	Load: 5,000 kg Min. lifting speed: 30 cm/min	-
Fire detection system:	available	available
Fire fighting system:	Handheld Extinguisher	Handheld Extinguisher
Shielding attenuation:	H-field: 10 kHz > 60 dB above 1 MHz > 100 dB	H-field: 10 kHz > 60 dB 100 kHz > 70 dB 1 MHz > 80 dB Plane Wave: 100 MHz > 100 dB 200 MHz > 200 dB 500 MHz > 100 dB 1 – 18 GHz > 80...60 dB
Absorber reflectivity:	70 MHz to 300 MHz >19 dB 300 MHz to 40 GHz >30 dB	Ferrite: 10 MHz – 1 GHz > 17 dB Pyramides: 100 MHz – 18 GHz > 20 dB
Power handling:	-1 kW/m <sup>2</sup> (600 V/m), continuously	1 kW/m <sup>2</sup> (600 V/m), continuously

<b>EMV Chamber 3</b>	
Length x width x height: Max. floor load:	4.6 m x 4.6 m x 2.7 m 50 kN/m <sup>2</sup>
Dimensions of door, width x height:	0.89 m x 1.9 m
Cleanliness class (ISO14644-1):	-
Temperature:	adjustable from 19 °C – 25 °C stability ± 1 °C
Relative humidity:	adjustable from 40 % - 60 % stability ± 1 °C
Compressed air and water supply:	available
Exhaust tail pipe:	available -
Fire detection and fighting system:	available
Fire fighting system:	Handheld Extinguisher
Shielding attenuation	H-field: 10 kHz > 40 dB 100 kHz >6 dB above 1 MHz > 80 dB
Plane Wave:	100 MHz > 80 dB 200 MHz > 100 dB 500 MHz > 800 dB 1 – 18 GHz > 80...60 dB
Absorber reflectivity:	100 MHz > 17 dB 300 MHz – 10 GHz > 20 dB
Power handling:	-1 kW / m <sup>2</sup> (600 V/m), continuously

### 3.2 Equipment for Emission Tests

Spectrum analysers with preselector:	up to 50 GHz
EMI receivers:	up to 40 GHz
Preamplifiers for low noise and notch measurement:	
Current probes:	up to 1 GHz
Antennas for magnetic and electric field measurement:	30 Hz to 50 GHz
Digital Storage Oscilloscope:	1 GS/s and 4 GS/s
Active current monitor:	DC – 50 MHz
Passive current monitor:	10 Hz - 100 MHz

### 3.3 Equipment for Susceptibility Tests

RF generators and synthesizers:	DC – 40 GHz
CW amplifier:	10 kHz – 220 MHz, 2 kW 220 MHz – 1 GHz, 500 W 1 GHz – 18 GHz, 200 W 18 GHz – 40 GHz, 1 W
Pulse amplifiers:	up to 5 kW
Stripline/ TEM-Cell:	300 MHz
E-Field generator:	10 kHz – 30 MHz
LogPer antenna:	100 MHz – 400 MHz
BiLog antenna:	30 MHz – 1 GHz
Std. gain horns and double ridged horn antennas:	200 MHz – 40 GHz
Broadband dipole:	25 MHz – 200 MHz
E-Field indicator:	10 kHz – 18 GHz
E-Field indicator:	10 kHz – 60 GHz
Coupling/decoupling networks and LISNs:	MIL and RCTA Standard
Susceptibility software:	RSUS

HIRF TEST, Maximum Test Levels 1  $\mu$ s pulse width

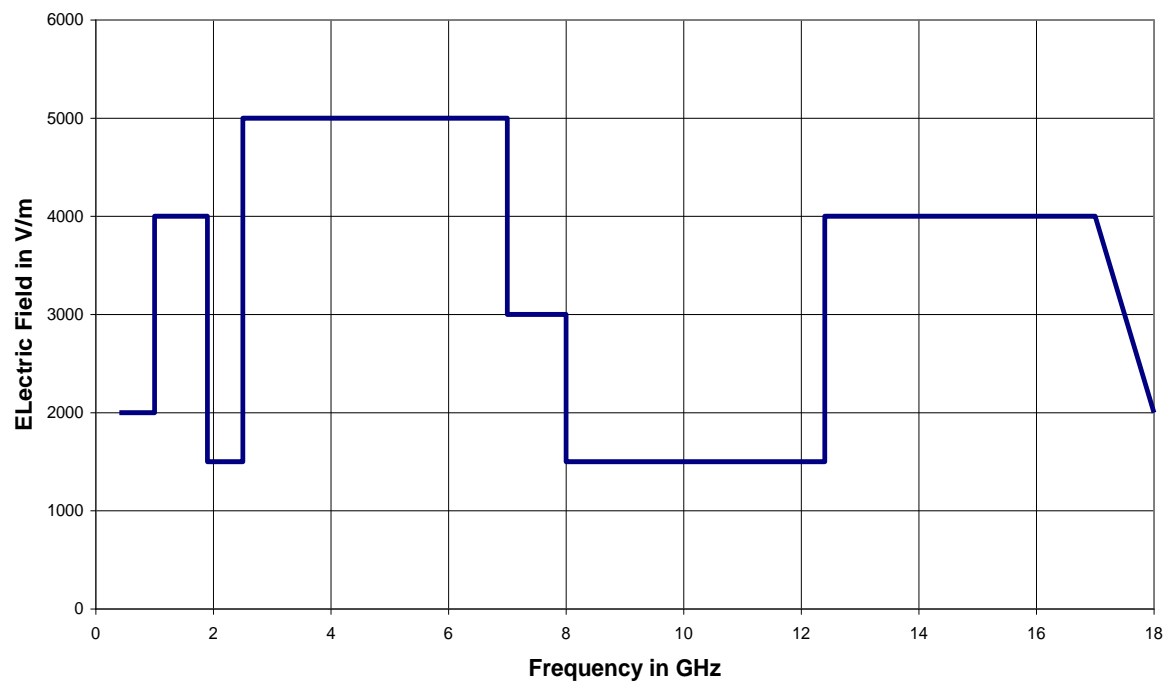

### 3.4 Time Domain

Arbitrary generator:	DC to 20 MHz
Bipolar Operational Amplifier 2000 W:	2,000 W
Automotive transients:	Pulse 1, 2, 3a+b, 4, 5
Damped sinusoidal transients:	up to 100 MHz
CS06 MIL-STD-461/462C:	10 $\mu$ s, 150 ns
CS116 MIL-STD-461/462D,E:	0.1 – 100 MHz
CS115 MIL-STD-461/462D,E:	30 ns
Lightning RTCA/DO-160C,D and ABD0100:	
wave 1 & 4:	6.4/70 $\mu$ s
wave 2:	0.1/6.4 $\mu$ s
wave 3:	1 MHz/10 MHz
wave 5A:	40/120 $\mu$ s
wave 5B:	50/500 $\mu$ s
Multiple Burst & Stroke, AC20-136, Airbus:	wave 1 – 5
Half Sine, ABD0007:	5 $\mu$ s
Fast pulse Eurofighter:	0.1/2 $\mu$ s
Communication pulse:	10/700 $\mu$ s
Surge, EN 61000-4-5:	1.2/50 – 8/20
Burst, EN-61000-4-4:	5/50 ns
ESD, EN 61000-4-2 and others:	150 pF/330 $\Omega$ (16 kV / Air) 150 pF/150 $\Omega$ (30 kV / Air) 100 pF/1,5 k $\Omega$ (16 kV / Air)

### 3.5 Power Supply for Customer Equipment and Test Articles

230 V/400 V/50 Hz 32A, 63A, max. 300A/phase:	Internal
115 V/200 V/400 Hz, 40 kVA:	Mechanical converter
115 V/200 V/DC – 2kHz, 90 kVA:	Electronic converter
3 x 0 – 400 V DC/AC, 15 kVA, DC – 1 kHz	programmable DC/AC power supply
3 x 0 – 400 V DC/AC, 45 kVA, DC – 1 kHz	programmable DC/AC power supply
0 – 60 V/30 A:	DC Power Supply



0 – 150 V/DC 15 A:

DC Power Supply

0 – 40 VDC/250A

DC Power Supply

*Product Qualification*

## Magnetic Test Facility

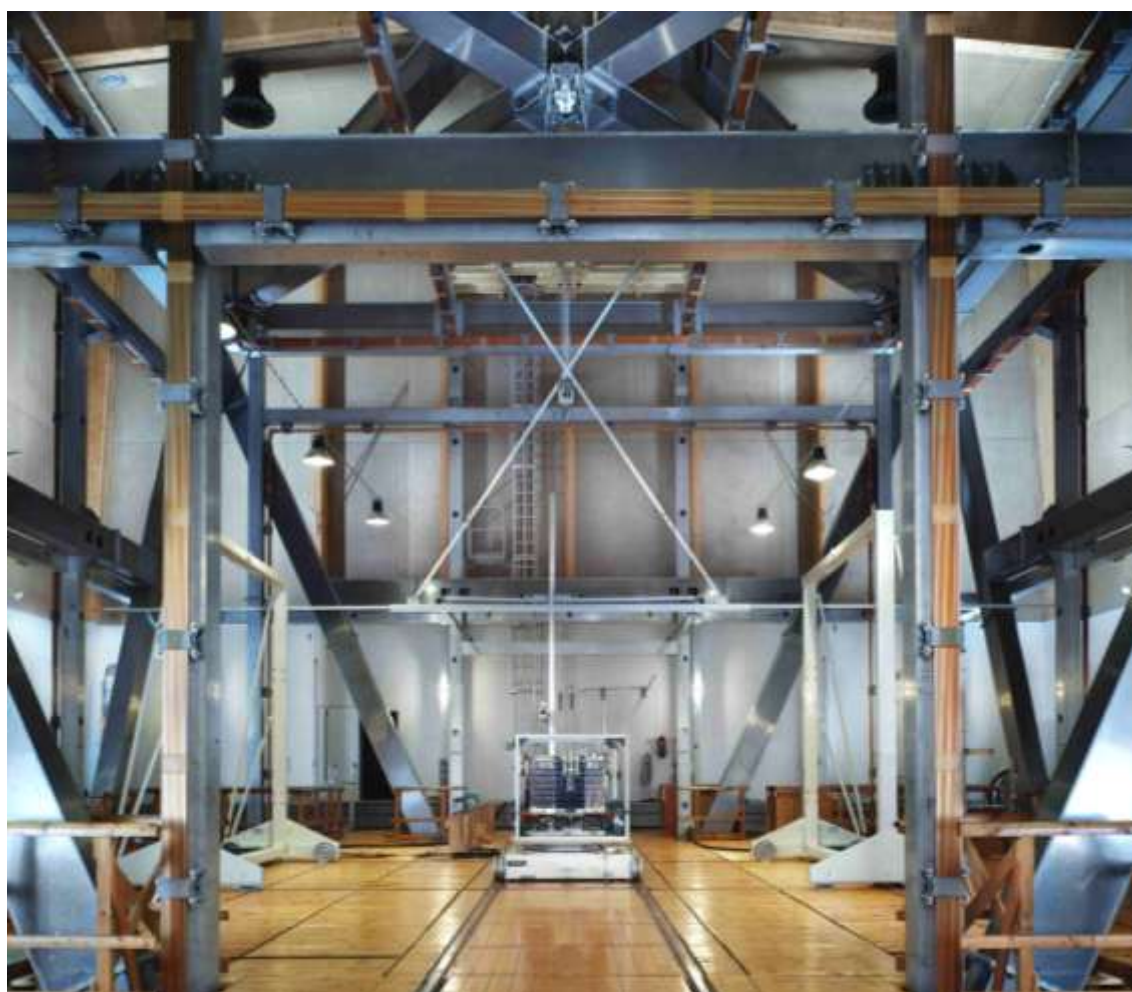

*Magnetic Test Facility*

## 1. Tasks

- Measuring the DC and AC magnetic cleanliness of test objects
- Magnetising and demagnetising of test objects to determine permanent, remanent and induced magnetic fields
- Measuring the dipole/multipole field distribution surrounding the test objects
- Modelling and predicting of far fields of a test object
- Modelling DC magnetic fields of a complex system based on several unit measurements
- Technical consulting for magnetic cleanliness
- Measuring of magnetic moments
- Measuring of eddy current fields
- Attitude control testing of magnetically stabilised spacecraft systems
- Calibration of magnetometers
- Compass safe distance test
- EN 61000-4-8/9/10 up to 1,000 A/m
- ISO 10373 and ISO 78 16 800 kA/m
- Immunity at 16 2/3, 50 and 400 Hz

## 2. Test Facility

The facility located within a magnetically clean and quiet area was built completely from non-magnetic materials such as non-reinforced concrete, glass foam, wood and non-ferromagnetic metals.

This unique facility in Europe represents the state-of-the-art technology for magnetic testing and enables the customer to perform DC and AC magnetic compatibility and susceptibility tests.

For this purpose a large variety of coil systems can be used with magnetic fields of different size, intensity and frequency, depending on the requirements given.

Standard data acquisition hardware with special software and experienced personnel ensure successful testing from materials to integrated spacecraft.

### 3. Technical Data

#### 3.1 Large coil system

Type:	Square coil system, 4 coils per axis, 3 orthogonal axes
Dimensions:	15 m x 15 m x 15 m, free access area 4 m x 4 m (height x width)
Zero Field:	Compensation of the earth's field with a resolution of 0.1 nT Uniformity * <sup>1</sup> : 5.0 nT in 4 m diameter, Stability of facility: 0.5 nT/hour
D.C. Field:	Range: 0 to 75,000 nT in each axis with a resolution of 0.1 nT Accuracy: 1 nT
A.C. Field:	Frequency range: 0.01 to 3 Hz Amplitude range: 0 to 75,000 nT resp. 100,000 nTHz *  Frequency range: 3 to 3,600 Hz Amplitude range: 0 to 10,000 nTHz

\* nTHz is a unit related to the induction law:  $U = - dB/dt$ : i.e. voltage is change of the flux density per second. Example: 1,000 nTHz is equal to 1 nT at 1,000 Hz or 1,000 nT at 1 Hz. <sup>1</sup> Additional externally generated magnetic field gradients have to be taken into account separately

### 3.2 Test Hall

Temperature:	adjustable from 19 °C – 25 °C stability $\pm 1$ °C
Relative humidity:	adjustable from 40 % - 60 % stability $\pm 1$ °C
Hoisting equipment in Anteroom:	16 m travel Load 1.500 kg Hook height 5 m
Hoist in facility center	Loag: 1.000 kg Hook height: 10 m
Trolley	Load: 1.500 kg Moveable on rails within facility With turn table

### 3.3 Magnetisation and Demagnetisation

Square Helmholtz coil system	
Dimension:	3.7 m x 3.7 m, horizontal field
Uniformity:	30 % in 3.0 m diameter, horizontal field
Magnetisation:	with D.C. fields of 1 to 4,000 A/m.
Demagnetisation:	with A.C. fields Start. amplit. of 160 to 4,000 A/m
Duration of demagnetisation: typically 10 min	depending on requirements,
Residual field:	< 0.25 A/m

Further coil systems and power supplies exist for different demagnetisation volumes and levels.

### 3.4 Magnetometer

#### Values for information only, please request data sheets for details

Fluxgate magnetometer with triple or single probes  
(second harmonics measurement)

D.C. application: Range: 0 to 100,000 nT  
Accuracy: 1 % resp. 1 nT  
Resolution: 0.2 nT

Protonspin magnetometer  
(Nuclear precision)

D.C. application: Omnidirectional  
Range: 20,000 to 120,000 nT

<p>Search coil magnetometer (ferrite loop antenna)</p> <p>A.C. application:</p>	<p>Accuracy: 0.3 nT Resolution: 0.01 nT</p> <p>Frequency range: 1 Hz to 60 KHz Amplitude range: 0 to 10,000 nTHz Accuracy: 1 dB resp. 0.5 nTHz</p>
---	--

*Product Qualification*

## Mass Properties Measurements



*High Precision Mass Properties Determination on a Driver Cabin of a Truck*

## 1. Tasks

For any kind of general engineering systems up to 6 metric tons, a series of facilities are available for the accurate determination of mass properties.

They comprise:

- Mass (weight)
- Centre of gravity (CoG)
- Moments and Products of Inertia (Mol, Pol)
- Static/dynamic unbalances (Pol)

## 2. Test Facilities

For the measurement of the different kinds of mass properties IABG provides various measurement devices such as high precision weight scales, unstable gravitational CoG scales, air bearing Mol oscillating tables, and vertical axis balancing machines.

The difficult measurement of the vertical axis CoG respectively of the Mol around the horizontal axes can be performed by using an L-shaped adapter with pivoted interface. This so called L-adapter allows the determination of lateral axes Mol which is fundamental for the calculation of the product of inertia of the horizontal plane. The Pol of the vertical planes can be calculated by measuring the unbalances of the test article.



### 3. Technical Data

#### 3.1 Weight Scales

Weight Range:	Accuracy:
up to 60 kg	± 2 g
up to 600 kg	± 20 g
up to 1,000 kg	± 100 g (up to 600 kg ± 50 g)
up to 3,000 kg	± 200 g (up to 1,000 kg ± 100 g)
up to 6,000 kg	± 500 g

#### 3.2 Centre of Gravity Scales

Weight Range:	Accuracy:
0.7 – 20 kg	± 0.3 mm
20 – 6,000 kg	± 0.5 mm

#### 3.3 Oscillating Tables for Mol

Mol Range: Mass Range	Accuracy:	
0.002 – 1.0 kgm <sup>2</sup>	± 1 %	small equipment
1.0 – 2,000 kgm <sup>2</sup>	± 0.5 %	2,000 kg
150 – 28,000 kgm <sup>2</sup>	± 0.5 %	6,000 kg

#### 3.4 Balancing Machines

Weight Range:	Rotation Speed:	Accuracy:
up to 1,400 kg	20 – 160 RPM	stat.: 70 – 0.35 kgmm dyn.: 0.02 – 10 <sup>-4</sup> kgm <sup>2</sup>
up to 2,800 kg	20 – 160 RPM	stat.: 140 – 0.7 kgmm dyn.: 0.2 – 10 <sup>-3</sup> kgm <sup>2</sup>

*Product Qualification*

## Calibration Laboratories



*Calibration of an accelerometer*

## 1. Tasks

IABG runs a DAkkS (German Accreditation Body) accredited calibration laboratory for vibration instruments. At this lab, we calibrate the following accelerometers both for customers as well as for internal use :

- Single or triaxial sensors
- Piezoresistive sensors
- Piezoelectric sensors

- IEPE type sensors
- Shock sensors

Also complete measurement chains which comprise sensors, charge amplifiers, and IEPE measuring amplifiers can be calibrated at DAkkS level.

## 2. Calibration Procedures

Facilities for sinusoidal and shock calibration of accelerometers are available at IABG. In both cases a comparison method is used, i.e. the calibration is related to a reference standard.

These primary standards are calibrated optically by interferometric methods at the National Metrology Institute PTB (Physikalisch-Technische Bundesanstalt) in Braunschweig, Germany.

The following standards are relevant for the calibration:

- DIN EN/ISO 17025  
General requirements for the competence of testing and calibration laboratories (IABG has continuously been accredited according to this standard since 1979).
- ISO 16063  
Methods for the calibration of vibration and shock transducers.
- IEEE P1451.4  
Standard for a smart transducer interface for sensors and actuators - mixed-mode communication protocols and transducer electronic data sheet (TEDS) format.

### 3. Calibration Facility Performance

Calibration Device:	Type of Excitation:	Measuring Range:	Frequency Range:	Minimum Uncertainty:
Sensors	Sine	up to 20 g (200 m/s <sup>2</sup> )	10 Hz – 5 kHz >5 kHz – 10 kHz @ 80 Hz @ 160 Hz	Ampl. 1.0 % Ampl. 2.0 % Ampl. 0.5 % Ampl. 0.5 %
Sensors	Sine	up to 1 g (10 m/s <sup>2</sup> )	0.5 Hz – 1 Hz  >1 Hz – 20 Hz  > 20 Hz – 100 Hz	Ampl. 0.8 % Phase 0.5 °  Ampl. 0.5 % Phase 0.5 °  Ampl. 0.8 % Phase 2.0 °
Sensors	Shock	up to 10,000 g (100,000 m/s <sup>2</sup> )  20 g – 150 g > 150 g – 1,000 g > 1,000 g – 10,000 g		Ampl. 1.0 % Ampl. 1.5 % Ampl. 5.0 %
Charging and Signal Amplif.	Sine	Voltage Amplitude 1 mV to 30 V resp.  Charge Amplitude 0.1 to 10,000 pC	10 kHz – 30 kHz > 30 kHz – 50 kHz  0.5 Hz – 10 kHz	Ampl. 0.6 % Ampl. 1.0 %  Ampl. 0.3 %
Shaker	Sine	up to 20 g (200 m/s <sup>2</sup> )	@ 80 Hz or @ 160 Hz 10 Hz – 5 kHz > 5 kHz – 10 kHz	Ampl. 1.0 % Ampl. 2.0 % Ampl. 3.0 %